

LOCH

Fräsen • Milling

mit Diamant- und CBN-Werkzeugen
with Diamond and CBN Cutting Tools



LACH DIAMOND INC.
4350 Airwest Drive, S.E.
Grand Rapids, MI, 49512 USA

Phone +1 (616) 698-0101
Fax +1 (616) 698-0232
www.lachdiamond.com
office@lachdiamond.com



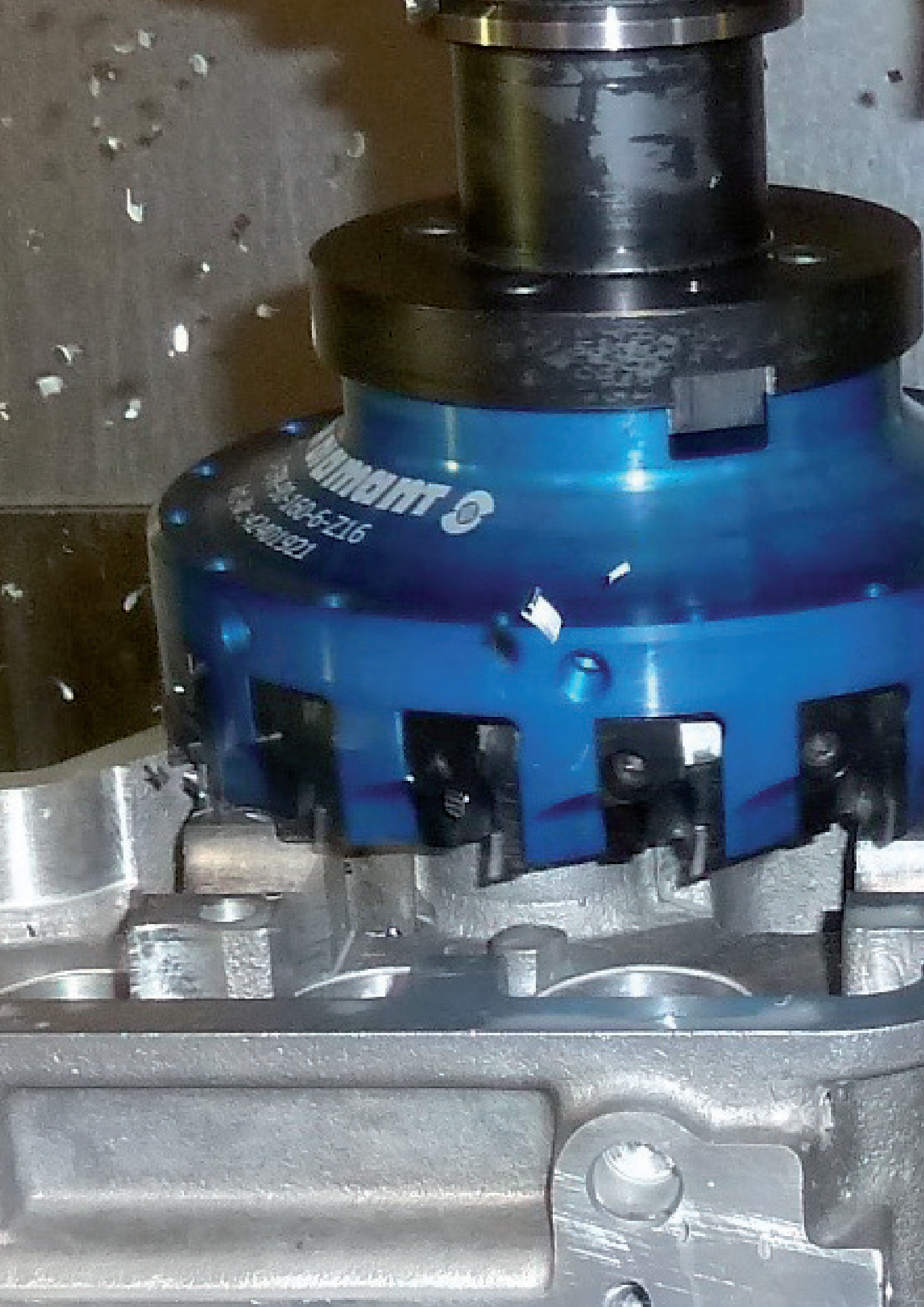

WALDMONT

917-6-216
174-4201921

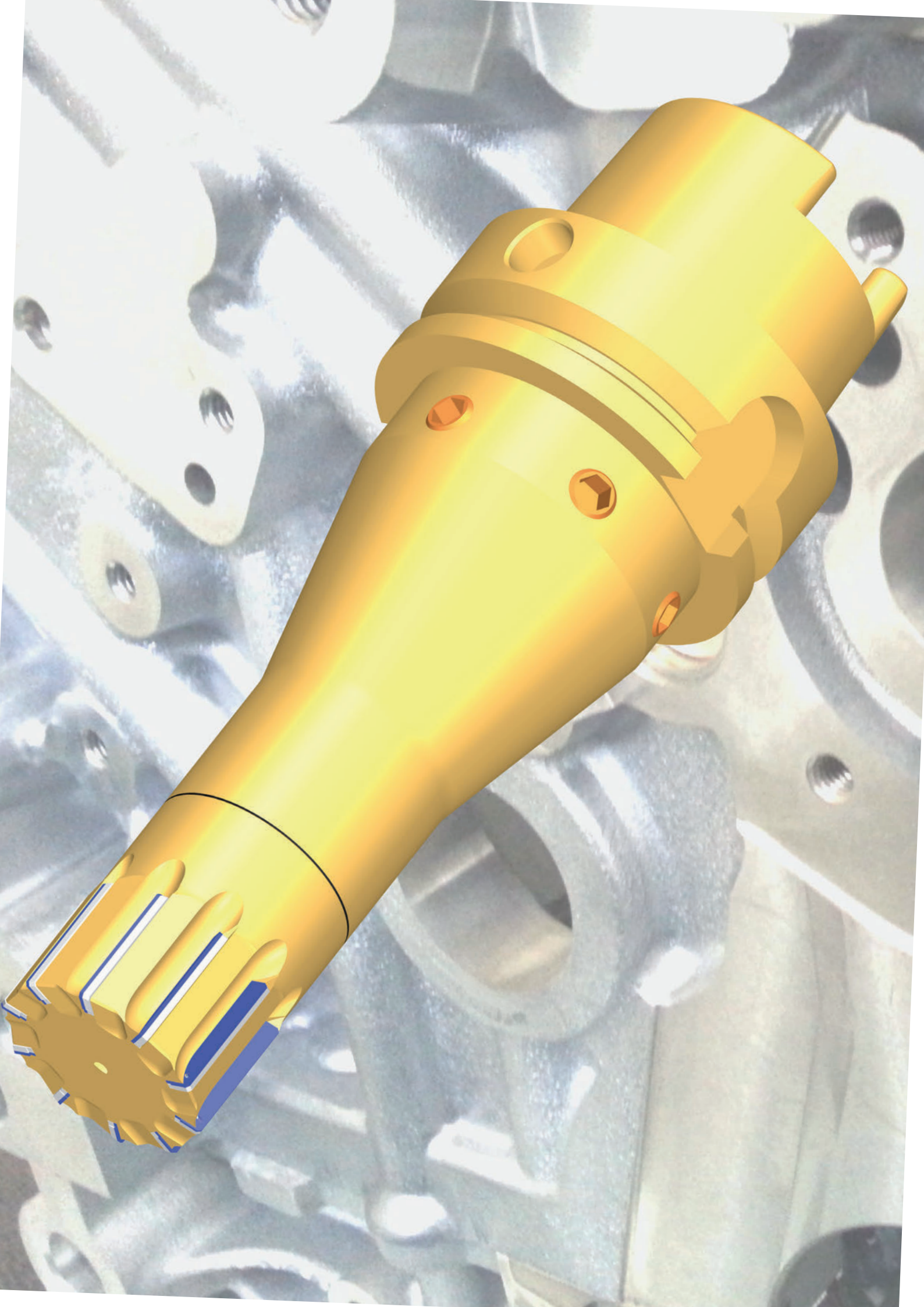

Inhaltsverzeichnis Table of Content

	Seite Page
PKD-Schaftfräser <i>PCD end mill</i>	6
PKD-Schaftfräser mit positivem Spanwinkel <i>PCD end mill with positive cutting angle</i>	7
PKD-Vielzahn-Schaftfräser mit definierten Schneiden <i>PCD multiple end mill with defined cuts</i>	8
PKD-Vielzahn-Schaftfräser mit Schruppschneiden <i>PCD end mill for roughing</i>	9
PKD-Schaftfräser mit Wechsel-Achswinkel <i>PCD end mill with alternated shear cut application</i>	10
PKD- und CBN-Kopierfräser <i>PCD and CBN copy milling cutter</i>	11 - 13
»dia-compact«-Monoblock-Diamant-Einschraubfräser <i>»dia-compact« Monoblock diamond screw-in milling cutter</i>	14 - 17
System »Cool-Injection« (Pat.) - Kühlung direkt <i>System »Cool Injection« (pat.) - direct cooling</i>	18
»dia-compact«-Monoblock-Diamant-HSC-Plan-Eckfräser <i>»dia-compact« Monoblock diamond HSC face and square shoulder milling cutter</i>	19 - 20
»dia-compact«-Monoblock-Diamant-Planfräser und Plan-Eckfräser <i>»dia-compact« Monoblock diamond face milling cutter and face and square shoulder milling cutter</i>	21 - 22
»dia-compact«-Monoblock-Diamant-Superfinish-Plan-Eckfräse <i>»dia-compact« Monoblock diamond superfinish face and square shoulder milling cutter</i>	23
PKD-Kassettenfräser »dia-blue-power« <i>PCD cartridge milling cutter »dia-blue-power«</i>	24 - 25
PKD-Frässchneidplatten <i>PCD Milling inserts</i>	26 - 27
Richtlinien für den Einsatz von PKD- und CBN-Werkzeugen <i>Application instructions for PCD and CBN tools</i>	28
Formelsammlung <i>Collection of formulas</i>	29

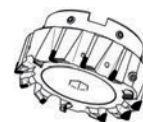
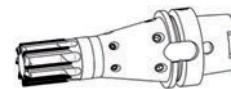
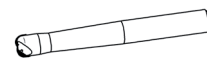
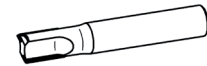

dreborid®
PKD-Schaftfräser
PCD End Mill

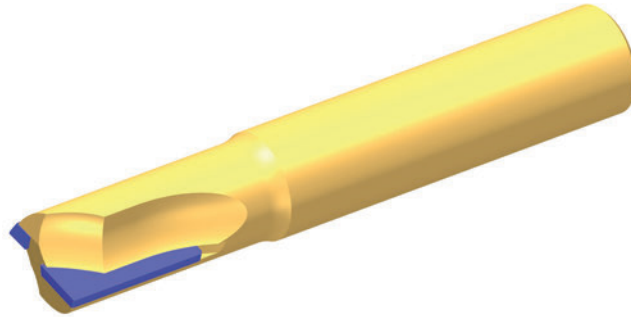

Empfohlen für alle Arten der Fräsbearbeitung von NE-Metallen und Kunststoffen
Recommended for all types of milling operations for non-ferrous metals and plastics

Type	Bestellcode Order Code	Baumaße nach ISO 1641 Dimensions according to ISO 1641					Art. No.
		D1	D2	L	A	Z	
SMS Mantel- und stirnschneidend <i>side and face cutting</i>	D-SMS-06-08	06	06	52	08	02	42400410
	D-SMS-08-11	08	08	61	11	02	42400385
	D-SMS-10-13	10	10	63	13	02	42400407
	D-SMS-12-16	12	12	73	16	02	42400408
	D-SMS-16-19	16	16	79	19	02	42401273
	D-SMS-06-13	06	06	57	13	02	42401274
	D-SMS-08-19	08	08	69	19	02	42401275
	D-SMS-10-22	10	10	72	22	02	42401276
	D-SMS-12-26	12	12	83	26	02	42401277
	D-SMS-16-32	16	16	92	32	02	42401278

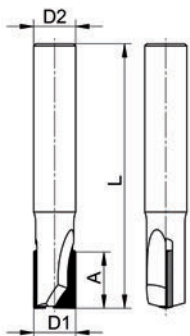

SMSA
Mantel- und stirnschneidend mit Achswinkel
side and face cutting with shear angle

D-SMSA-06-08	06	06	52	08	02	42400360
D-SMSA-08-11	08	08	61	11	02	42400383
D-SMSA-10-13	10	10	63	13	02	42400371
D-SMSA-12-16	12	12	73	16	02	42400406
D-SMSA-16-19	16	16	79	19	02	42401279
D-SMSA-06-13	06	06	57	13	02	42401280
D-SMSA-08-19	08	08	69	19	02	42401281
D-SMSA-10-22	10	10	72	22	02	42401282
D-SMSA-12-26	12	12	83	26	02	42401283
D-SMSA-16-32	16	16	92	32	02	42401284

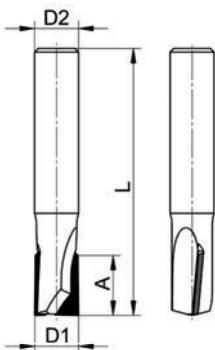

Andere Abmessungen maßgeschneidert nach Ihrer Vorgabe.
Custom-made dimensions according to your specifications.

PKD-Schaftfräser mit positivem Spanwinkel PCD End Mill with positive cutting angle

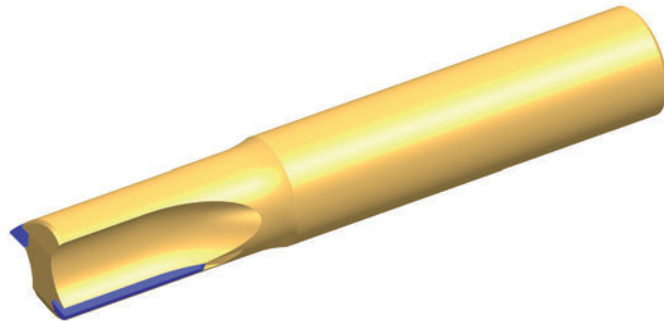

Empfohlen für besonders empfindliche und dünnwandige Bauteile aus NE-Metallen und Kunststoffen
Recommended for particularly sensitive and thin-walled components made of non-ferrous metals and plastics

Type	Bestellcode Order Code	Baumaße nach ISO 1641 Dimensions according to ISO 1641					Art. No.
		D1	D2	L	L2	A	
SMP	D-SMP-06-08	06	06	52	36	8	42402300
Mantelschneidend mit positivem Schnitt side cutting with positive cut	D-SMP-08-11	08	08	61	36	11	42402301
	D-SMP-10-13	10	10	63	40	13	42402302
	D-SMP-12-16	12	12	73	45	16	42402303
	D-SMP-16-19	16	16	79	48	19	42402304
	D-SMP-06-13	06	06	57	36	13	42402305
	D-SMP-08-19	08	08	69	36	19	42402306
	D-SMP-10-22	10	10	72	40	22	42402307
	D-SMP-12-26	12	12	83	45	26	42402308
	D-SMP-16-32	16	16	92	48	32	42402309

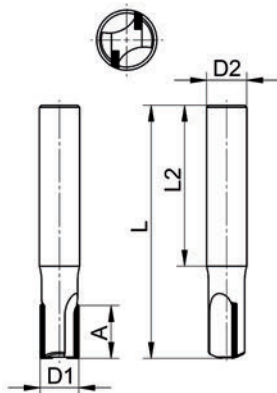

Andere Abmessungen maßgeschneidert nach Ihrer Vorgabe.
Custom-made dimensions according to your specifications.

dreborid®

PKD-Vielzahn-Schaftfräser mit definierten Schneiden

PCD multiple End Mill with defined cuts

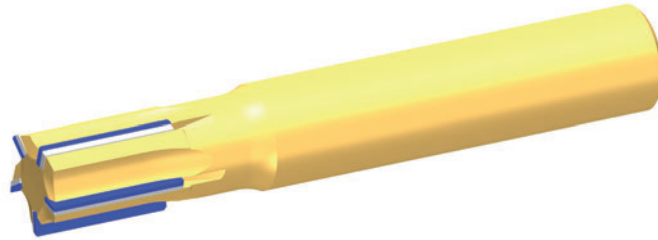

Empfohlen zum Schlichten von Bauteilen aus NE-Metallen und Kunststoffen

Recommended for the finishing of components made of non-ferrous metals and plastics

Type	Bestellcode <i>Order Code</i>	Baumaße nach <i>Dimensions according to</i>				ISO 1641 DIN 844		Art. No.
		D1	D2	L	L2	A	Z	
SMM	D-SMM-08-11-03	08	08	61	36	11	03	42401850
	D-SMM-08-11-05	08	08	61	36	11	05	42401851
	D-SMM-10-13-03	10	10	63	40	13	03	42401852
	D-SMM-10-13-05	10	10	63	40	13	05	42401853
	D-SMM-12-16-03	12	12	73	45	16	03	42401854
	D-SMM-12-16-05	12	12	73	45	16	05	42401855
	D-SMM-12-16-07	12	12	73	45	16	07	42401856
	D-SMM-16-19-03	16	16	79	48	19	03	42401857
	D-SMM-16-19-05	16	16	79	48	19	05	42401858
	D-SMM-16-19-07	16	16	79	48	19	07	42401859
	D-SMM-16-19-09	16	16	79	48	19	09	42401860
	D-SMM-08-19-03	08	08	69	36	19	03	42401861
	D-SMM-08-19-05	08	08	69	36	19	05	42401862
	D-SMM-10-22-03	10	10	72	40	22	03	42401863
	D-SMM-10-22-05	10	10	72	40	22	05	42401864
	D-SMM-12-26-03	12	12	83	45	26	03	42401865
	D-SMM-12-26-05	12	12	83	45	26	05	42401866
	D-SMM-12-26-07	12	12	83	45	26	07	42401867
	D-SMM-16-32-03	16	16	92	48	32	03	42401868
	D-SMM-16-32-05	16	16	92	48	32	05	42401869
	D-SMM-16-32-07	16	16	92	48	32	07	42401870
	D-SMM-16-32-09	16	16	92	48	32	09	42401871

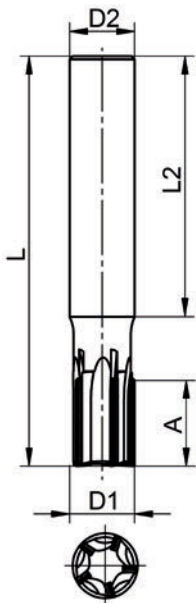

Andere Abmessungen maßgeschneidert nach Ihrer Vorgabe.
Custom-made dimensions according to your specifications.

Nachschleifservice für alle PKD- und CBN-Werkzeuge

PKD-Vielzahn-Schaftfräser mit Schrupp-Schneiden PCD multiple End Mill for roughing

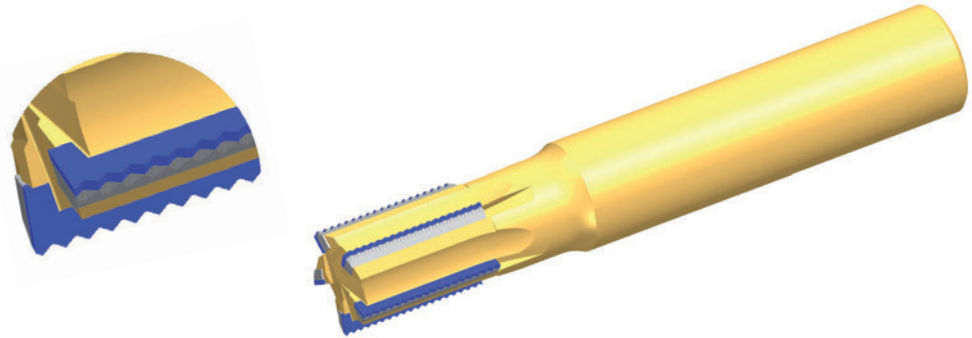

Empfohlen zum Schruppen von Bauteilen aus NE-Metallen und Kunststoffen

Recommended for the roughing of components made of non-ferrous metals and plastics

Type	Bestellcode Order Code	Baumaße nach Dimensions according to				ISO 1641 DIN 844		Art. No.
		D1	D2	L	L2	A	Z	
SMV	D-SMV-08-11-03	08	08	61	36	11	03	42406040
	D-SMV-08-11-05	08	08	61	36	11	05	42400866
	D-SMV-10-13-03	10	10	63	40	13	03	42402688
	D-SMV-10-13-05	10	10	63	40	13	05	42402619
	D-SMV-12-16-03	12	12	73	45	16	03	42403433
	D-SMV-12-16-05	12	12	73	45	16	05	42402623
	D-SMV-12-16-07	12	12	73	45	16	07	42403434
	D-SMV-16-19-03	16	16	79	48	19	03	42403435
	D-SMV-16-19-05	16	16	79	48	19	05	42403436
	D-SMV-16-19-07	16	16	79	48	19	07	42403437
	D-SMV-16-19-09	16	16	79	48	19	09	42403438
	D-SMV-08-19-03	08	08	69	36	19	03	42403439
	D-SMV-08-19-05	08	08	69	36	19	05	42402624
	D-SMV-10-22-03	10	10	72	40	22	03	42403440
	D-SMV-10-22-05	10	10	72	40	22	05	42403441
	D-SMV-12-26-03	12	12	83	45	26	03	42403442
	D-SMV-12-26-05	12	12	83	45	26	05	42403443
	D-SMV-12-26-07	12	12	83	45	26	07	42403444
	D-SMV-16-32-03	16	16	92	48	32	03	42403445
	D-SMV-16-32-05	16	16	92	48	32	05	42403446
	D-SMV-16-32-07	16	16	92	48	32	07	42403447
	D-SMV-16-32-09	16	16	92	48	32	09	42403448

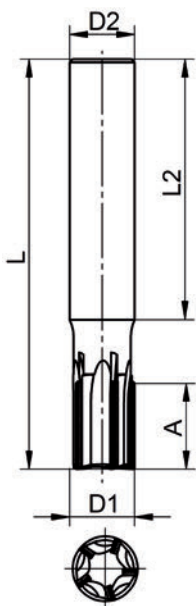

Andere Abmessungen maßgeschneidert nach Ihrer Vorgabe.
Custom-made dimensions according to your specifications.

dreborid®

PKD-Schafffräser mit Wechsel-Achswinkel

PCD End Mill with alternated shear cut application

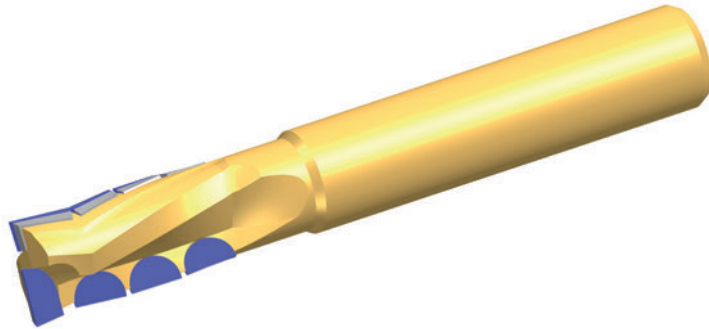

Empfohlen für saubere Kantenbearbeitung von NE-Metallen und Kunststoffen

Recommended for fine finished edges of non-ferrous metals and plastics

Type	Bestellcode Order Code	Baumaße nach ISO 1641 Dimensions according to ISO 1641					Art. No.
		D1	D2	L	L2	A	
SMS-WA	D-SMSWA-10-22	10	10	72	40	22	42401880
	D-SMSWA-12-26	12	12	83	45	26	42401881
	D-SMSWA-16-32	16	16	92	48	32	42401882
	D-SMSWA-20-38	20	20	104	50	38	42401883

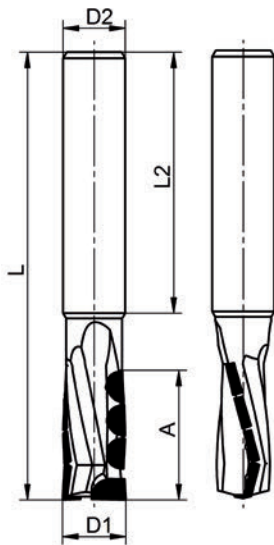

Andere Abmessungen maßgeschneidert nach Ihrer Vorgabe.
Custom-made dimensions according to your specifications.

Nachschleifservice für alle PKD- und CBN-Werkzeuge

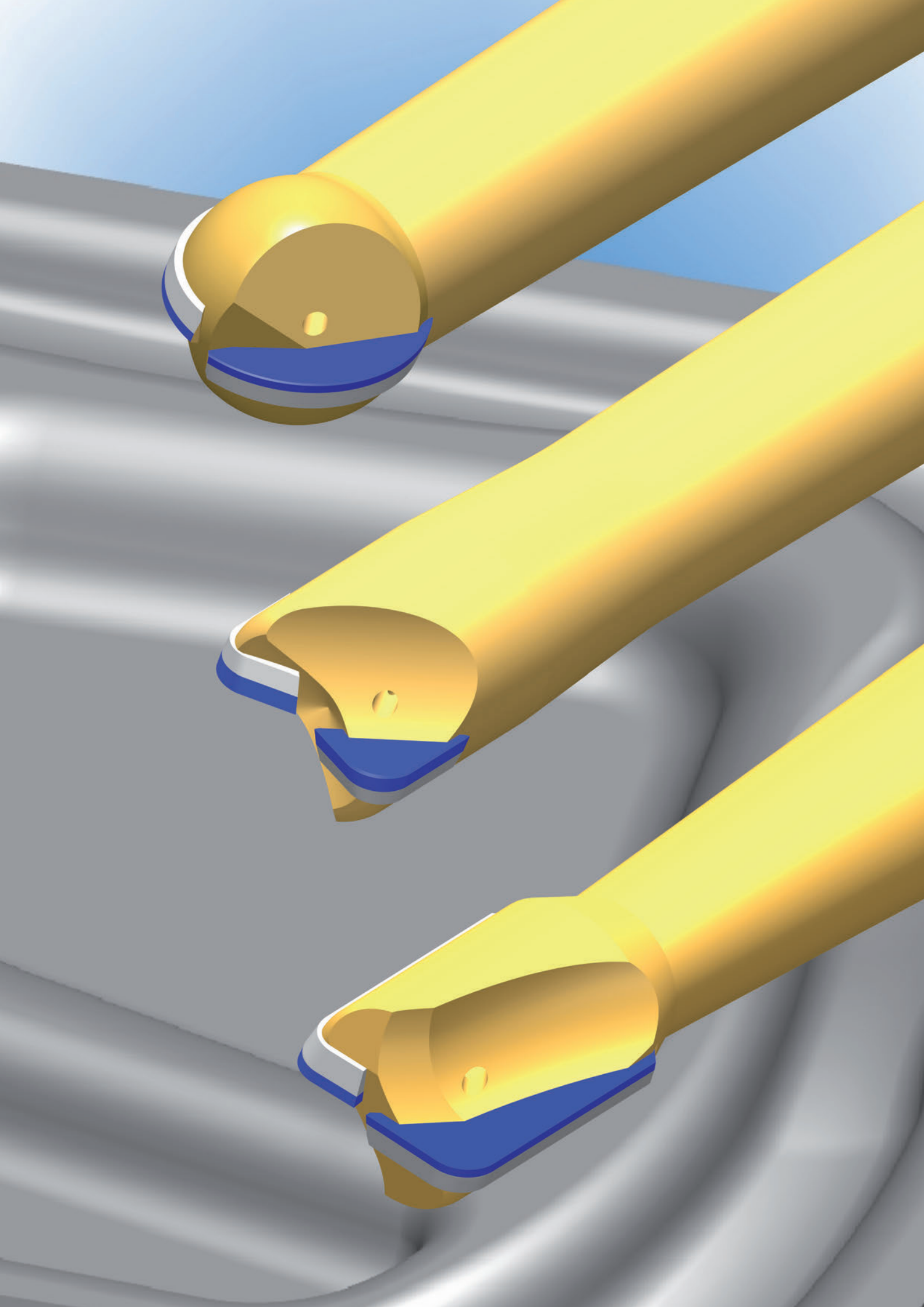

dreborid®

PKD-Kopierfräser mit Innenkühlung

PCD Copy Milling Cutter with internal cooling

Empfohlen für die 3-D-Bearbeitung von Formen aus NE-Metallen, Kunststoffen und Graphit

Recommended for 3-D processing of moulds made of non-ferrous metals, plastics and graphite

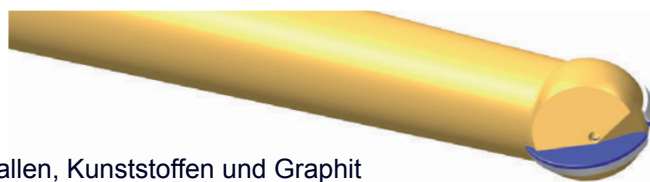

Type	Bestellcode Order Code	Baumaße Dimensions							Art. No.
		D1	D2	R	L	L2	L3	A	
SMSR PKD-Schafffräser mit Eckenradius <i>PCD corner radius end mill</i>	D-SMSR-06-10-65	6	6	1,0	65	28	37	6	42405010
	D-SMSR-08-10-80	8	8	1,0	80	43	37	8	42405011
	D-SMSR-10-15-95	10	10	1,5	95	53	42	10	42405012
	D-SMSR-12-15-105	12	12	1,5	105	48	47	12	42405013
	D-SMSR-16-20-125	16	16	2,0	125	73	52	16	42405014
	D-SMSR-06-10-80	6	6	1,0	80	43	37	6	42405015
	D-SMSR-08-10-95	8	8	1,0	95	58	37	8	42405016
	D-SMSR-10-15-110	10	10	1,5	110	68	42	10	42405017
	D-SMSR-12-15-125	12	12	1,5	125	78	47	12	42405018
	D-SMSR-16-20-160	16	16	2,0	160	108	52	16	42405019



Type	Bestellcode Order Code	D1	D2	R	L	L2	L3	Art. No.
SRT PKD-Torusfräser <i>PCD toric end mill</i>	D-SRT-06-10-65	6	6	1,0	65	28	37	42405020
	D-SRT-08-20-80	8	8	2,0	80	43	37	42405021
	D-SRT-10-30-95	10	10	3,0	95	53	42	42405022
	D-SRT-12-40-105	12	12	4,0	105	48	47	42405023
	D-SRT-16-50-125	16	16	5,0	125	73	52	42405024
	D-SRT-06-10-80	6	6	1,0	80	43	37	42405025
	D-SRT-08-20-95	8	8	2,0	95	58	37	42405026
	D-SRT-10-30-110	10	10	3,0	110	68	42	42405027
	D-SRT-12-40-125	12	12	4,0	125	78	47	42405028
	D-SRT-16-50-160	16	16	5,0	160	108	52	42405029

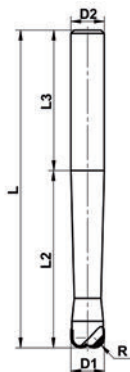

SRS PKD-Kugelfräser <i>PCD ball-nose end mill</i>	D-SRS-06-30-65	6	6	3,0	65	28	37	42405030
	D-SRS-08-40-80	8	8	4,0	80	43	37	42405031
	D-SRS-10-50-95	10	10	5,0	95	53	42	42405032
	D-SRS-12-60-105	12	12	6,0	105	48	47	42405033
	D-SRS-16-80-125	16	16	8,0	125	73	52	42405034
	D-SRS-06-30-80	6	6	3,0	80	43	37	42405035
	D-SRS-08-40-95	8	8	4,0	95	58	37	42405036
	D-SRS-10-50-110	10	10	5,0	110	68	42	42405037
	D-SRS-12-60-125	12	12	6,0	125	78	47	42405038
	D-SRS-16-80-160	16	16	8,0	160	108	52	42405039



Optional mit »Cool Injection« (Pat.) – Bestellbeispiel: D-SRTi-06-10-65

Optional with »Cool Injection« (pat.) – Example for ordering: D-SRTi-06-10-65

Andere Abmessungen maßgeschneidert nach Ihrer Vorgabe.

Custom-made dimensions according to your specifications.

Nachschleifservice für alle PKD- und CBN-Werkzeuge

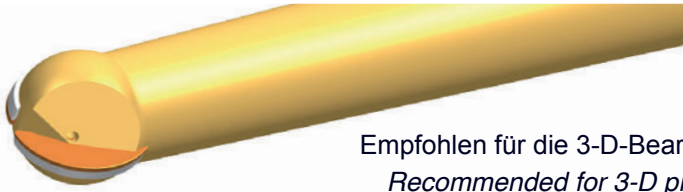

CBN-Kopierfräser mit Innenkühlung CBN Copy Milling Cutter with internal cooling

Empfohlen für die 3-D-Bearbeitung von Formen aus vergütetem und gehärtetem Stahl
Recommended for 3-D processing of moulds made of hardened and tempered steel

Type	Bestellcode Order Code	Baumaße Dimensions							Art. No.
		D1	D2	R	L	L2	L3	A	
SMSR CBN-Schafffräser mit Eckenradius <i>CBN corner radius end mill</i>	B-SMSR-06-10-65	6	6	1,0	65	28	37	6	43400120
	B-SMSR-08-10-80	8	8	1,0	80	43	37	8	43400121
	B-SMSR-10-15-95	10	10	1,5	95	53	42	10	43400122
	B-SMSR-12-15-105	12	12	1,5	105	48	47	12	43400123
	B-SMSR-16-20-125	16	16	2,0	125	73	52	16	43400124
	B-SMSR-06-10-80	6	6	1,0	80	43	37	6	43400130
	B-SMSR-08-10-95	8	8	1,0	95	58	37	8	43400131
	B-SMSR-10-15-110	10	10	1,5	110	68	42	10	43400132
	B-SMSR-12-15-125	12	12	1,5	125	78	47	12	43400133
	B-SMSR-16-20-160	16	16	2,0	160	108	52	16	43400134

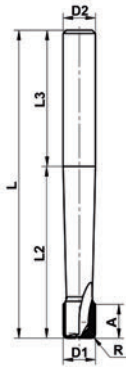

Type	Bestellcode Order Code	D1	D2	R	L	L2	L3	Art. No.
SRT CBN-Torusfräser <i>CBN toric end mill</i>	B-SRT-06-10-65	6	6	1,0	65	28	37	43400140
	B-SRT-08-20-80	8	8	2,0	80	43	37	43400141
	B-SRT-10-30-95	10	10	3,0	95	53	42	43400142
	B-SRT-12-40-105	12	12	4,0	105	48	47	43400143
	B-SRT-16-50-125	16	16	5,0	125	73	52	43400144
	B-SRT-06-10-80	6	6	1,0	80	43	37	43400150
	B-SRT-08-20-95	8	8	2,0	95	58	37	43400151
	B-SRT-10-30-110	10	10	3,0	110	68	42	43400152
	B-SRT-12-40-125	12	12	4,0	125	78	47	43400153
	B-SRT-16-50-160	16	16	5,0	160	108	52	43400154
SRS CBN-Kugelfräser <i>CBN ball-nose end mill</i>	B-SRS-06-30-65	6	6	3,0	65	28	37	43400160
	B-SRS-08-40-80	8	8	4,0	80	43	37	43400161
	B-SRS-10-50-95	10	10	5,0	95	53	42	43400162
	B-SRS-12-60-105	12	12	6,0	105	48	47	43400163
	B-SRS-16-80-125	16	16	8,0	125	73	52	43400164
	B-SRS-06-30-80	6	6	3,0	80	43	37	43400170
	B-SRS-08-40-95	8	8	4,0	95	58	37	43400171
	B-SRS-10-50-110	10	10	5,0	110	68	42	43400172
	B-SRS-12-60-125	12	12	6,0	125	78	47	43400173
	B-SRS-16-80-160	16	16	8,0	160	108	52	43400174

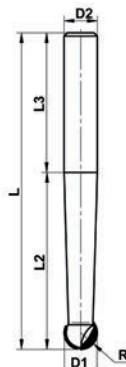

Optional mit »Cool Injection« (Pat.) – Bestellbeispiel: D-SRTi-06-10-65

Optional with »Cool Injection« (pat.) – Example for ordering: D-SRTi-06-10-65

Andere Abmessungen maßgeschneidert nach Ihrer Vorgabe.

Custom-made dimensions according to your specifications.

Resharpener service for all PCD and CBN cutting tools

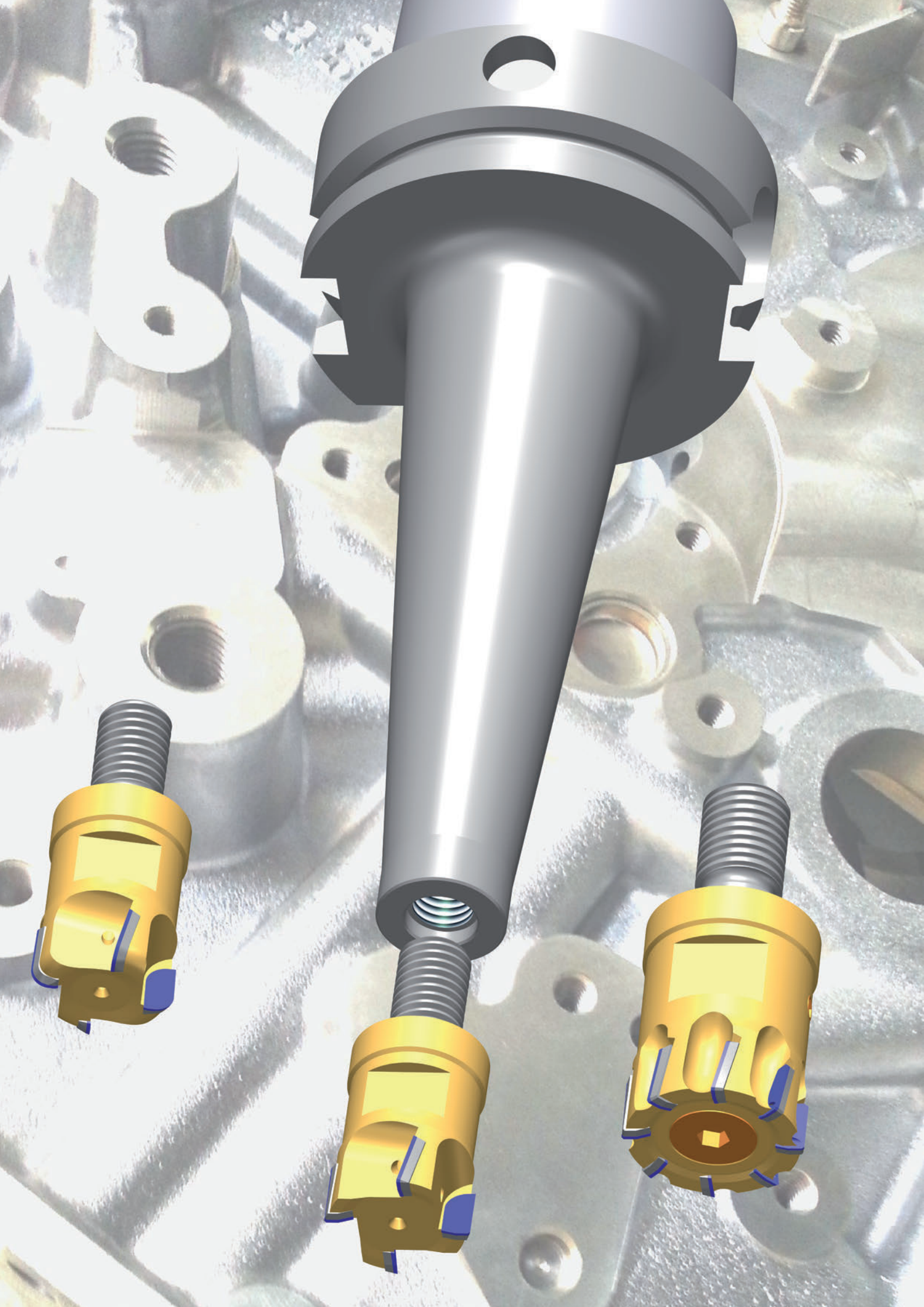

» dia-compact«-Monoblock-Diamant-Einschraubfräser mit Innenkühlung
 »dia-compact« Monoblock diamond screw-in Milling Cutter with internal cooling

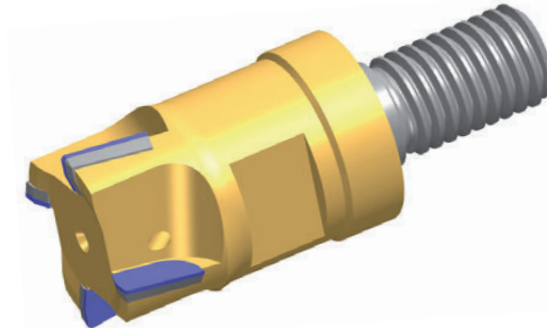

Empfohlen für die HSC-Bearbeitung in der Produktion von NE-Metallen und Kunststoffen - GFK - CFK
 Recommended for the HSC machining in the production of non-ferrous metals and plastics - GRP - CFRP

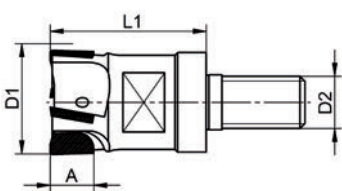
Type	Bestellcode Order Code	Baumaße Dimensions					Art. No.
		D1	D2	L1	A	Z	
MB-E 	D-MB-E0-90-16-8-Z3-M8	16	M8	25	8	3	42502010
	D-MB-E0-90-20-8-Z4-M10	20	M10	30	8	4	42502011
	D-MB-E0-90-25-8-Z4-M12	25	M12	35	8	4	42502012
	D-MB-E0-90-32-8-Z6-M16	32	M16	40	8	6	42502013

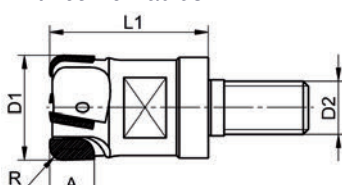
Type	Bestellcode Order Code	D1	D2	R	L1	A	Z	Art. No.
		MB-E mit Eckenradius with corner radius 	D-MB-E0-90-16-8-R2-Z3-M8	16	M8	2	25	
	D-MB-E0-90-20-8-R2-Z4-M10	20	M10	2	30	8	4	42502021
	D-MB-E0-90-25-8-R3-Z4-M12	25	M12	3	35	8	4	42502022
	D-MB-E0-90-32-8-R4-Z6-M16	32	M16	4	40	8	6	42502023

Die Aufnahmen wählen Sie auf Seite 17.
 Please see on page 17 for the adapter.

Andere Abmessungen maßgeschneidert nach Ihrer Vorgabe.
 Custom-made dimensions according to your specifications.

dreborid®

Monoblock-Diamant-Einschraubfräser mit »Cool Injection« und Spanabweiser »Plus«

Monoblock diamond screw-in Milling Cutter with »Cool Injection« and Chipbreaker »Plus«

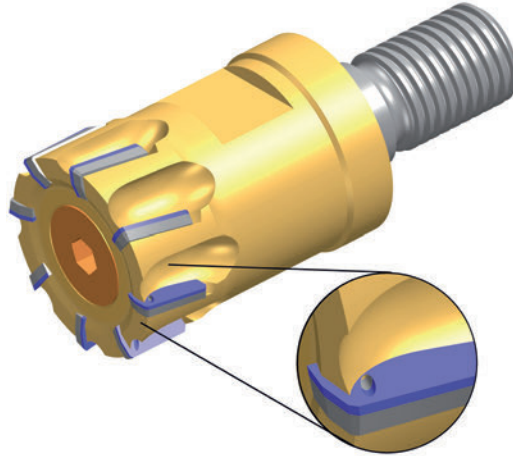

Für innovative HSC-/HPC-Aluminium-Zerspanung
For innovative HSC/HPC aluminium machining

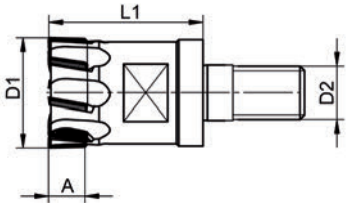
Type	Bestellcode <i>Order Code</i>	Baumaße <i>Dimensions</i>					Art. No.
		D1	D2	L1	A	Z	
MB-E 	D-MB-E3-16-8-Z5-M8	16	M8	25	8	5	42502040
	D-MB-E3-20-8-Z6-M10	20	M10	30	8	6	42502041
	D-MB-E3-25-8-Z8-M12	25	M12	35	8	8	42502042
	D-MB-E3-32-8-Z10-M16	32	M16	40	8	10	42502043

Die Aufnahmen wählen Sie auf Seite 17.
Please see on page 17 for the adapter.

Andere Abmessungen maßgeschneidert nach Ihrer Vorgabe.
Custom-made dimensions according to your specifications.

Aufnahme HSK 63A mit Innenkühlung für Einschraubfräser Adapter HSK 63A with internal cooling for screw-in Milling Cutter

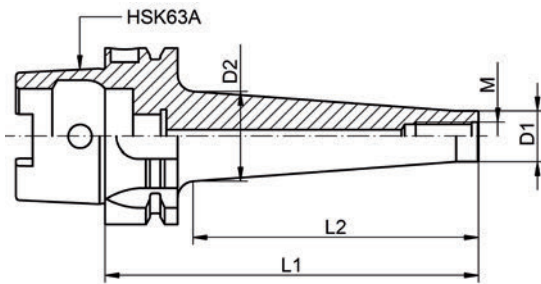

Bestellcode Order Code	Baumaße Dimensions					Art. No.
	M	D1	D2	L1	L2	
HSK63A-51-M8	8	13,8	15	51	25	42510500
HSK63A-101-M8	8	13,8	25	101	75	42510501
HSK63A-51-M10	10	18	23	51	25	42510502
HSK63A-101-M10	10	18	30	101	75	42510503
HSK63A-126-M10	10	18	35	126	100	42510504
HSK63A-51-M12	12	21	24	51	25	42510505
HSK63A-101-M12	12	21	35	101	75	42510506
HSK63A-151-M12	12	21	43	151	125	42510507
HSK63A-176-M12	12	21	45	176	150	42510508
HSK63A-51-M16	16	29	34	51	25	42510509
HSK63A-101-M16	16	29	35	101	75	42510510
HSK63A-151-M16	16	29	44	151	125	42510511
HSK63A-176-M16	16	29	48	176	150	42510512

Zylinderschaftaufnahme mit Innenkühlung für Einschraubfräser schwingungsgedämpft durch VHM-Kern Cylindrical adapter with internal cooling for screw-in Milling Cutter with damped oscillation through solid carbide core

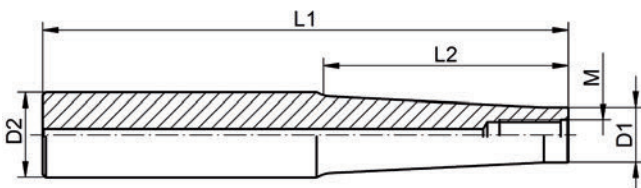

Bestellcode Order Code	D1	D2	L1	L2	M	Art. No.
16h6-80-M8	13	16	135	80	M8	42510520
16h6-100-M8	13	16	155	100	M8	42510521
16h6-120-M8	13	16	175	120	M8	42510522
20h6-100-M10	18	20	160	100	M10	42510523
20h6-140-M10	18	20	200	140	M10	42510524
25h6-100-M12	21	25	165	100	M12	42510525
32h6-100-M16	29	32	170	100	M16	42510526
32h6-150-M16	29	32	220	150	M16	42510527

Resharpener service for all PCD and CBN cutting tools

System »Cool Injection« (Pat.)

Kühlung direkt
direct cooling

Ihr Weg zur optimalen Zerspanung von NE-Metallen und Kunststoffen
Your way to the optimum machining of non-ferrous metals and plastics



· Hochgeschwindigkeits-Zerspanen
· *High speed cutting (HSC)*

· Perfekte Späneabfuhr
· *Perfect chip removal*

· Maximale Vorschübe und Spantiefen
· *Maximum feeds and depths of cut*

· Beste Oberflächenqualität bei Vor- und Fertigbearbeitung
· *Best surface quality for pre- and finish-machining*

· Längere Werkzeugstandzeiten und höhere Wirtschaftlichkeit
· *Longer tool life and better economy*

» dia-compact«-Monoblock-Diamant-HSC-Plan-Eckfräser mit Innenkühlung
 » dia-compact« Monoblock diamond HSC face and square shoulder
 Milling Cutter with internal cooling

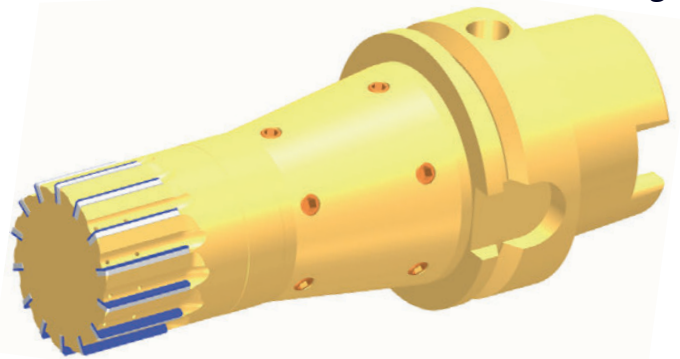

Empfohlen für die HSC-Bearbeitung in der Produktion von NE-Metallen und Kunststoffen;
 durch die hohe Schneidenzahl enorme Zerspanungsleistung und Taktzeitreduzierung
 Recommended for HSC machining in the production of non-ferrous metals and plastics;
 enormous cutting performance and reduction of cycle times due to the large number of cutting edges

Type	Bestellcode Order Code	Baumaße Dimensions					Aufnahme Adapter	Art. No.
		D1	A	L	L2	Z		
MB-H	D-MB-H0-90-30-15-100-Z8 HSK63A	30	15	100	35	8	HSK 63 A	42502000
	D-MB-H0-90-35-15-120-Z10 HSK63A	35	15	120	35	10	HSK 63 A	42502001
	D-MB-H0-90-40-15-150-Z10 HSK63A	40	15	150	35	10	HSK 63 A	42502002
	D-MB-H0-90-50-15-150-Z12 HSK63A	50	15	150	35	12	HSK 63 A	42502003
	D-MB-H0-90-63-15-150-Z16 HSK63A	63	15	150	35	16	HSK 63 A	42502004

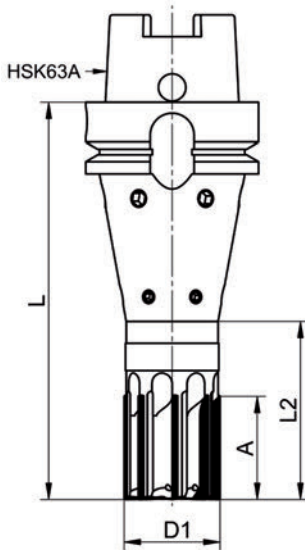

Alternative Aufnahmen HSK 80A/ HSK 100A und SK 40 / SK 50
 Alternative adapters HSK 80A / HSK 100A and SK 40 / SK 50

Andere Abmessungen maßgeschneidert nach Ihrer Vorgabe.
 Custom-made dimensions according to your specifications.

dreborid®

» dia-compact«-Monoblock-Diamant-HSC-Plan-Eckfräser
 mit » Cool Injection« und Spanabweiser » plus«
 » dia-compact« Monoblock diamond HSC face and square shoulder
 Milling Cutter with » Cool Injection« and Chipbreaker » plus«

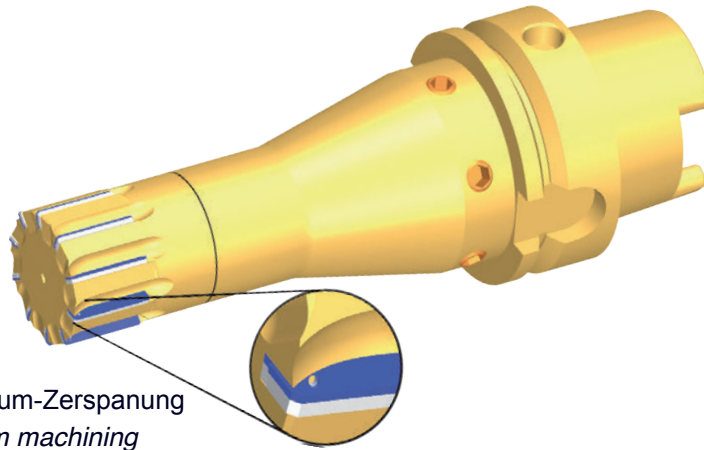

Für innovative HSC-HPC-Aluminium-Zerspanung
 For innovate HSC/HPC aluminium machining

Type	Bestellcode Order Code	Baumaße Dimensions					Aufnahme Adapter	Art. No.
		D1	A	L	L2	Z		
MB-H	D-MB-H3-90-30-15-100-Z8 HSK63A	30	15	100	35	8	HSK 63 A	42502050
	D-MB-H3-90-35-15-120-Z10 HSK63A	35	15	120	35	10	HSK 63 A	42502051
	D-MB-H3-90-40-15-150-Z10 HSK63A	40	15	150	35	10	HSK 63 A	42502052
	D-MB-H3-90-50-15-150-Z12 HSK63A	50	15	150	35	12	HSK 63 A	42502053
	D-MB-H3-90-63-15-150-Z16 HSK63A	63	15	150	35	16	HSK 63 A	42502054

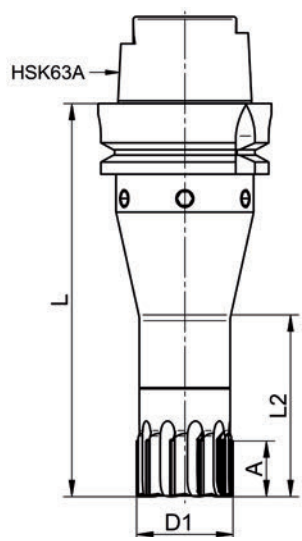

Alternative Aufnahmen HSK 80A/ HSK 100A und SK 40 / SK 50
 Alternative adapters HSK 80A / HSK 100A and SK 40 / SK 50

Andere Abmessungen maßgeschneidert nach Ihrer Vorgabe.
 Custom-made dimensions according to your specifications.

Nachschleifservice für alle PKD- und CBN-Werkzeuge

» dia-compact«-Monoblock-Diamant-Planfräser
 » dia-compact« Monoblock diamond face Milling Cutter

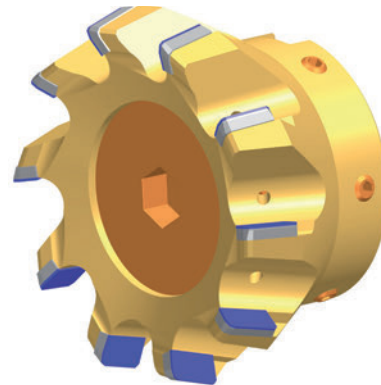
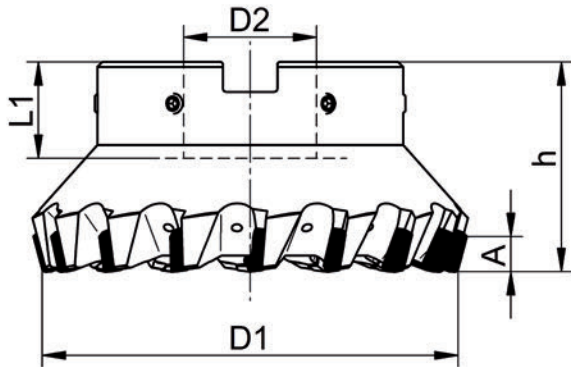

Empfohlen für die HSC-Bearbeitung in der Produktion von NE-Metallen und Kunststoffen
 Recommended for HSC machining in the production of non-ferrous metals and plastics

Type	Bestellcode Order Code	Baumaße nach ISO 6462 Dimensions according to ISO 6462						Art. No.	
		D1	h	A	D2	L1	Z		
MB-X 75 Anstellwinkel 75° Lead angle	D-MB-X0-75-040-08-Z5 / F	40	40	8	16	21	5	42500101	
	D-MB-X0-75-040-08-Z5 / P							42500102	
	D-MB-X0-75-040-08-Z5 / R							42500103	
	D-MB-X0-75-050-08-Z6 / F	50	40	8	16	21	6	42500201	
	D-MB-X0-75-050-08-Z6 / P							42500202	
	D-MB-X0-75-050-08-Z6 / R							42500203	
	D-MB-X0-75-063-08-Z8 / F	63	45	8	22	21	8	42500301	
	D-MB-X0-75-063-08-Z8 / P							42500302	
	D-MB-X0-75-063-08-Z8 / R							42500303	
	D-MB-X0-75-080-10-Z10 / F	80	50	10	27	23	10	42500401	
	D-MB-X0-75-080-10-Z10 / P							42500402	
	D-MB-X0-75-080-10-Z10 / R							42500403	
	D-MB-X0-75-100-10-Z12 / F	100	50	10	32	26	12	42500501	
	D-MB-X0-75-100-10-Z12 / P							42500502	
	D-MB-X0-75-100-10-Z12 / R							42500503	
	D-MB-X0-75-125-10-Z16 / F	125	63	10	40	29	16	42500601	
	D-MB-X0-75-125-10-Z16 / P							42500602	
	D-MB-X0-75-125-10-Z16 / R							42500603	
	Oberflächengüten Surface finish	D-MB-X0-75-160-10-Z20 / F	160	63	10	40	29	20	42500701
		D-MB-X0-75-160-10-Z20 / P							42500702
D-MB-X0-75-160-10-Z20 / R								42500703	
D-MB-X0-75-200-13-Z24 / P		200	63	13	40	26	24	42500802	

Hinweis: »dia-compact«-Monoblock-Diamant-Fräser für die HSC-Bearbeitung sind für die Aufnahme in Ihrem Adapter vorgewuchtet. Alternativ liefern wir den Adapter Ihrer Wahl komplett montiert und feinstgewuchtet oder einteilig.

Note: »dia-compact« Monoblock diamond cutters for HSC machining are pre-balanced for the tool attachment in your adapter. Alternatively we supply the adapter of your choice completely mounted and precision-balanced or as one-piece.

Resharpener service for all PCD and CBN cutting tools

dreborid®

» dia-compact« Monoblock-Diamant-Plan-Eckfräser

» dia-compact« Monoblock diamond face and square shoulder Milling Cutter

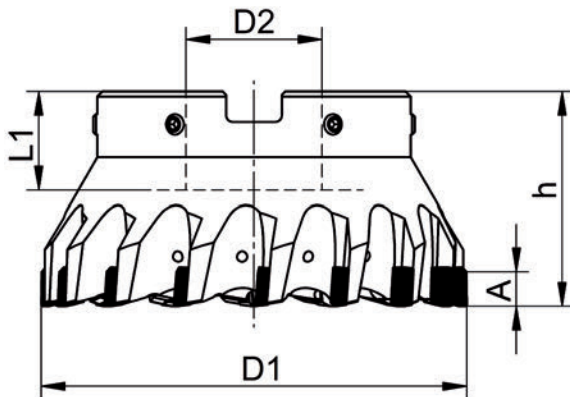

Empfohlen für die HSC-Bearbeitung in der Produktion von NE-Metallen und Kunststoffen
 Recommended for HSC machining in the production of non-ferrous metals and plastics

Type	Bestellcode Order Code	Baumaße nach ISO 6462 Dimensions according to ISO 6462						Art. No.
		D1	h	A	D2	L1	Z	
MB-X 90 Anstellwinkel 90° Lead angle	D-MB-X0-90-040-08-Z5 / F	40	40	8	16	21	5	42505101
	D-MB-X0-90-040-08-Z5 / P							42505102
	D-MB-X0-90-040-08-Z5 / R							42505103
	D-MB-X0-90-050-08-Z6 / F	50	40	8	16	21	6	42505201
	D-MB-X0-90-050-08-Z6 / P							42505202
	D-MB-X0-90-050-08-Z6 / R							42505203
	D-MB-X0-90-063-08-Z8 / F	63	45	8	22	21	8	42505301
	D-MB-X0-90-063-08-Z8 / P							42505302
	D-MB-X0-90-063-08-Z8 / R							42505303
	D-MB-X0-90-080-10-Z10 / F	80	50	10	27	23	10	42505401
	D-MB-X0-90-080-10-Z10 / P							42505402
	D-MB-X0-90-080-10-Z10 / R							42505403
Oberflächengüten Surface finish	D-MB-X0-90-100-10-Z12 / F	100	50	10	32	26	12	42505501
	D-MB-X0-90-100-10-Z12 / P							42505502
	D-MB-X0-90-100-10-Z12 / R							42505503
	D-MB-X0-90-125-10-Z16 / F	125	63	10	40	29	16	42505601
	D-MB-X0-90-125-10-Z16 / P							42505602
	D-MB-X0-90-125-10-Z16 / R							42505603
	D-MB-X0-90-160-10-Z20 / F	160	63	10	40	29	20	42505701
	D-MB-X0-90-160-10-Z20 / P							42505702
	D-MB-X0-90-160-10-Z20 / R							42505703
	D-MB-X0-90-200-13-Z24 / P	200	63	13	40	26	24	42505802

Hinweis: »dia-compact«-Monoblock-Diamant-Fräser für die HSC-Bearbeitung sind für die Aufnahme in Ihrem Adapter vorgewuchtet. Alternativ liefern wir den Adapter Ihrer Wahl komplett montiert und feinstgewuchtet oder einteilig.

Note: »dia-compact« Monoblock diamond cutters for HSC machining are pre-balanced for the tool attachment in your adapter. Alternatively we supply the adapter of your choice completely mounted and precision-balanced or as one-piece.

» dia-compact«-Monoblock-Diamant-Superfinish-Plan-Eckfräser
 » dia-compact« Monoblock diamond superfinish face and square shoulder Milling Cutter

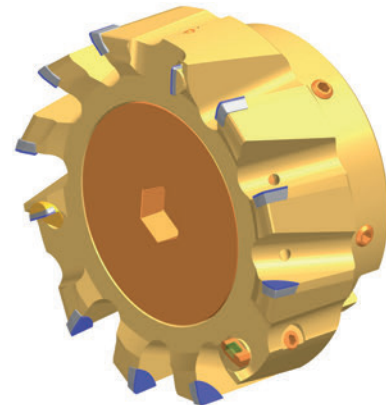
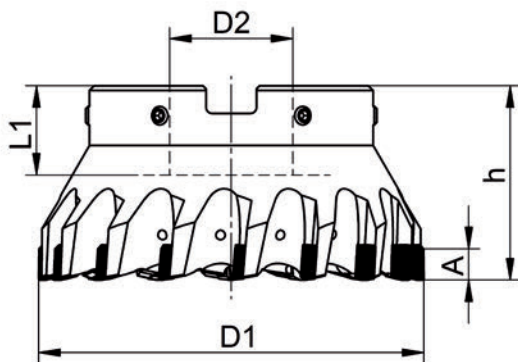

Empfohlen für Feinstbearbeitung und Hochglanzbearbeitung von NE-Metallen und Kunststoffen.
 Recommended for finish and super finish machining of non-ferrous metals and plastics.

Type	Bestellcode Order Code	Baumaße nach ISO 6462 Dimensions according to ISO 6462						Art. No.
		D1	h	A	D2	L1	Z	
MB-X 90 Anstellwinkel 90° Lead angle	D-MB-X0-90-040-8-Z5/FF	40	40	8	16	21	4/1	42502030
	D-MB-X0-90-050-8-Z6/FF	50	40	8	16	21	5/1	42502031
	D-MB-X0-90-063-8-Z8/FF	63	45	8	22	21	6/2	42502032
	D-MB-X0-90-080-10-Z10/FF	80	50	10	27	23	8/2	42502033
Oberflächengüten Surface finish $F = R_z < 5 \mu$	D-MB-X0-90-100-10-Z12/FF	100	50	10	32	26	9/3	42502034
	D-MB-X0-90-125-10-Z16/FF	125	63	10	40	29	12/4	42502035
	D-MB-X0-90-160-10-Z20/FF	160	63	10	40	29	16/4	42502036

Die Zähnezahl Z beinhaltet die Anzahl Schruppschneiden und Schlichtkassetten.
 Beispiel: Z = 6 / 2 (6 Schruppschneiden fest / 2 Schlichtkassetten einstellbar).

The number of teeth Z includes the number of cutting edges for roughing and finish cartridges.
 Example: Z = 6 / 2 (6 fixed cutting edges for roughing and 2 indexable finish cartridges).

Achtung: Für das Hochglanzbearbeiten benötigen Sie einen Schlichteinsatz mit Naturdiamant-Schneide und eine entsprechende Maschine.
Attention: For super finish machining you need an insert with MCD cutting edge for finishing and an appropriate machine.

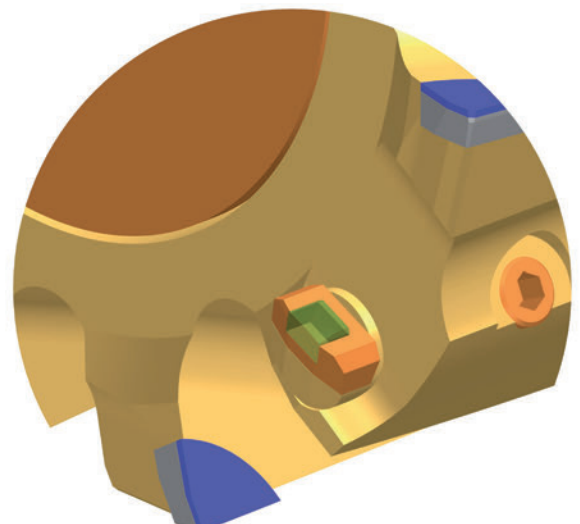

PKD-Kassettenfräser » dia-blue-power« PCD Cartridge Milling Cutter » dia-blue-power«



Max. Spantiefe - a_p bis 5 mm
Max. depth of cut - a_p up to 5 mm

Vorschub - V_f bis 30.000 mm/min
Feed - V_f up to 30.000 mm/min

Schnittgeschwindigkeit - V_c bis 6.000 m/min
Cutting speed - V_c up to 6.000 m/min

Taktzeitreduzierung bis zu 60%
Cycle time reduction up to 60%

Exzellente Bauteilqualität durch positiven Schnitt
Excellent quality of component due to positive cut

Geringe Spindelbelastung durch Aluminium-Grundkörper
Lower spindle load due to aluminium body

Wirtschaftliches Nachschliff-Konzept servicefreundlich - μm -genaue Einstellbarkeit
Economic regrinding concept
Service-focused - precise μm settings

Kassetten für Plan-Eckfräser Cartridges for face and square shoulder milling cutter

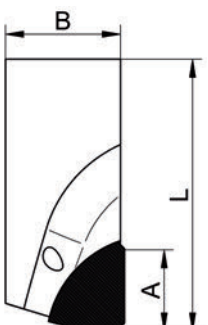
Type	Bestellcode Order Code	Baumaße Dimensions			Art. No.
		B	L	A	
CR 	Größe Size 1				
	D-CR 17x29-A10/P	17	29	10	42404730
	D-CR 17x29-A10/F	17	29	10	42404732
	D-CR 17x29-A10/FF	17	29	10	42404734
	Größe Size 2				
	D-CR 10x24-A6/P	10	24	6	42404731
	D-CR 10x24-A6/F	10	24	6	42404733
	D-CR 10x24-A6/FF	10	24	6	42404735

P= Standard-Kassette
Standard cartridge

F= Schlicht-Kassette
Finish cartridge

FF= Feinschlicht-Kassette
maximal 2-4 Kassetten im Planfräser
Super finish cartridge
max 2-4 cartridges in the face milling cutter

PKD-Kassettenfräser »dia-blue-power« PCD Cartridge Milling Cutter »dia-blue-power«

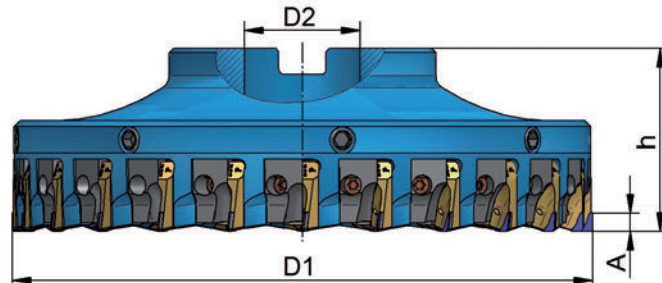

Empfohlen für Schrupp-, Schlicht- und Feinschlichtbearbeitung in der Produktion von NE-Metallen und Kunststoffen
Recommended for rough, finish and super finish machining in the production of non-ferrous metals and plastics

Type	Bestellcode Order Code	Baumaße Dimensions					Art. No.
		D1	h	A	D2	Z	
CFM für Kassetten-Größe 1 for cartridge size 1	CFM-90-160-10-Z14	160	63	10	40	14	42404720
	CFM-90-200-10-Z16	200	63	10	40	16	42404700
	CFM-90-240-10-Z20	240	63	10	40	20	42404704
	CFM-90-280-10-Z24	280	63	10	40	24	42404708
	CFM-90-315-10-Z28	315	83	10	40	28	42404712
	CFM-90-400-10-Z34	400	83	10	60	34	42404718
CFM für Kassetten-Größe 2 for cartridge size 2	CFM-90-100-06-Z10	100	63	6	32	10	42402800
	CFM-90-125-06-Z14	125	63	6	32	14	42401920
	CFM-90-160-06-Z20	160	63	6	40	18	42401921
	CFM-90-200-06-Z24	200	63	6	40	24	42401922
	CFM-90-240-06-Z30	240	63	6	40	30	42402804
	CFM-90-280-06-Z36	280	63	6	40	36	42402806
	CFM-90-315-06-Z42	315	83	6	40	42	42402828
	CFM-90-400-06-Z50	400	83	6	60	52	42402811

Hinweis: »dia-compact-Plan-Eckfräser mit Kassetten sind für die Aufnahme in Ihrem Adapter vorgewuchtet.

Alternativ liefern wir den Adapter Ihrer Wahl komplett montiert und feinstgewuchtet.

Note: »dia-compact« face and square shoulder milling cutters are pre-balanced for the tool attachment in your adapter. Alternatively we supply the adapter of your choice completely mounted and precision-balanced.

Der Bestellcode mit Art. No. beinhaltet den kompletten Fräser ohne PKD-Kassetten. Die Ausführung der Kassetten wählen Sie auf Seite 24.

The order code with Art. No. includes the complete milling cutter without PCD cartridge.

The version of the cartridges please see on page 24.

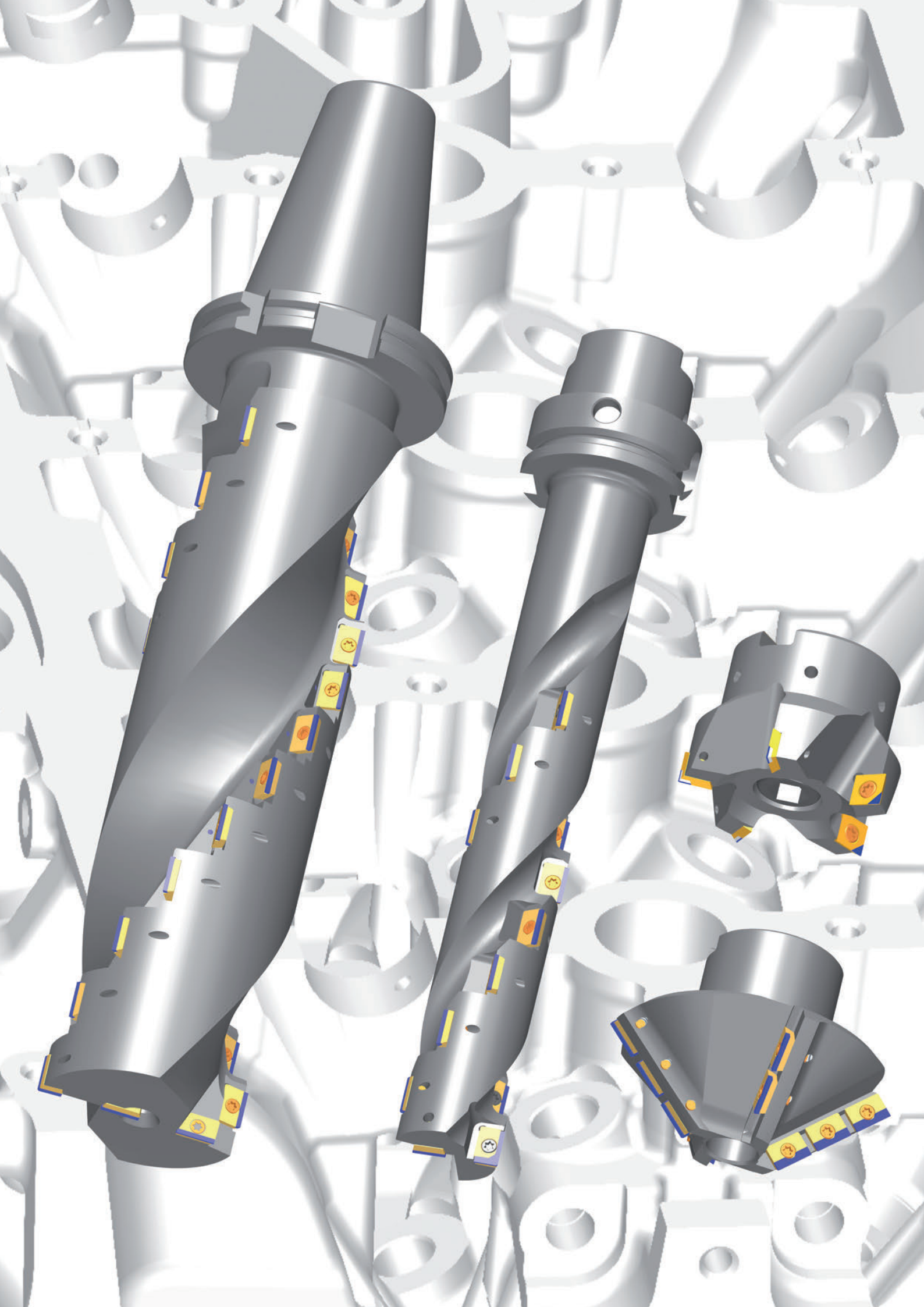

dreborid®
PKD-Frässchneidplatten
PCD Milling Inserts

Empfohlen für die Bearbeitung von NE-Metallen und Kunststoffen
Recommended for the machining of non-ferrous metals and plastics

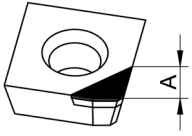
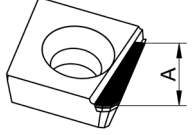
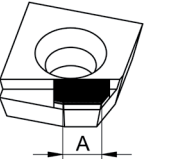
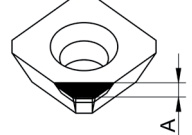
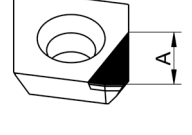
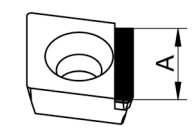
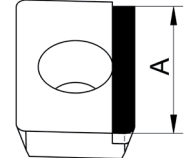
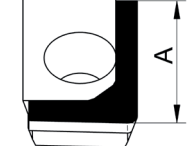
Type	Bestellcode Order Code	Art. No.
	D-SPGW 1204EDR/A5	42290041
	D-SFFW 1203 EFR	42220640
	D-SPGW 1204 EDR/A11	42220679
	D-SPGW 1204 EDL/A13-DL	42220680
	D-SPGW 1204XX/A5	42220393
	D-SPGW 1204 AEN/A4	42210756
	D-SEGW 1204 AFN/A4	42210980
	D-CPGW 1204 PDR/A6	42290062
	D-CPGW 1204PDR/A12	42671044
	D-LDMW 15T304/A15	42221575
	D-LDMW 15T308/A15	42221359
	D-LDMW 15T304/A15-A9	42221576
	D-LDMW 15T308/A15-A9	42221360

Weitere Frässhneidplatten nach ISO lieferbar.
Further types of milling inserts according to ISO available on request.

Resharping service for all PCD and CBN cutting tools

Richtlinien für den Einsatz

Application Instructions

polykristalliner Diamant-Werkzeuge (PKD)

polycrystalline diamond tools (PCD)

Werkstoff Material	Schnittwerte Cutting data		
	Schnittgeschw. Cutting speed $V_c = \text{m/min}$	Vorschub Infeed $f_n = \text{mm/U}$	Spantiefe Depth of cut $a_p = \text{mm}$
Aluminiumlegierungen unter 3 % Si <i>Aluminium alloys less than 3 % Si</i>	200 - 2000	0,05 - 0,4	bis zur Diamant- schneiden- höhe A up to the height of the diamond cutting edge A
Aluminiumlegierungen bis zu 12 % Si <i>Aluminium alloys up to 12 % Si</i>	150 - 1000	0,05 - 0,4	
Aluminiumlegierungen bis ca. 21 % Si <i>Aluminium alloys up to approx. 21 % Si</i>	100 - 800	0,05 - 0,4	
Messing-, Magnesium-, Zinklegierungen <i>Brass, magnesium, zinc alloys</i>	200 - 2000	0,05 - 0,4	
Kupfer-, Bronze-, Bleilegierungen <i>Copper, bronze, lead alloys</i>	200 - 1000	0,05 - 0,4	
Duro- und Thermoplaste ohne und mit Füllstoffen, z.B.: CFK, GFK und Epoxydharze <i>Duro and thermoplastics with and without fillers, e.g. CFRP, GRP and epoxy resin</i>	100 - 1000	0,05 - 0,2	
Hartpapiere <i>Hard papers</i>	200 - 600	0,10 - 0,3	
Hart- und Weichgummi ohne u. mit Füllstoffen <i>Hard and soft rubber with and without fillers</i>	100 - 500	0,10 - 0,3	
Graphit- und vorgesintertes Hartmetall <i>Graphite and pre-sintered carbide</i>	100 - 500	0,10 - 0,4	
Aluminiumoxyd, Silizium, Wolfram <i>Aluminium oxide, silicon, tungsten</i>	50 - 180	bis 0,1 up to 0,1	bis 0,5 up to 0,5

polykristalliner Bornitrid-Werkzeuge (CBN)

polycrystalline boron nitride tools (CBN)

Werkstoff Material	Schnittwerte Cutting data		
	Schnittgeschw. Cutting speed $V_c = \text{m/min}$	Vorschub Infeed $f_n = \text{mm/U}$	Spantiefe Depth of cut $a_p = \text{mm}$
Werkzeug- und Einsatzstähle <i>Tool and case hardened steels</i>	120 - 300	bis 0,4	bis 0,8
hochleg. Werkzeugstähle (CrNi) <i>High alloy hardened steels (CrNi)</i> pulvermetallurgische Stähle (ASP) <i>Powder metallurgic steels (ASP)</i>	60 - 220	bis 0,15	bis 1,0
Gusswerkstoff <i>Cast materials</i> GG; GGG, GTW, GH, GS	bis 900	bis 0,5	bis 2,0
Aufspritzlegierungen <i>Thermal sprayed alloys</i> Sonderlegierungen <i>Special alloys</i>	60 - bis 120	bis 2,0	bis 1,0

Für unterbrochenen Schnitt wählen Sie 50% der Schnittdaten. Intensive Kühlung mit KSS oder MMS verbessert die Schnittleistung.
For interrupted cuts use 50% of the cutting values. Intensive cooling with suitable coolant improves the cutting performance.

Formelsammlung Collection of formulas

Terminologie Terminology	Einheit Unit	Formel Formula
Fräsen Milling		
d = Fräserdurchmesser <i>Milling cutter diameter</i>	[mm]	$v_c = \frac{\pi \times D \times n}{1000}$
l_f = Bearbeitungslänge <i>Processing length</i>	[mm]	
a_p = Spantiefe <i>Depth of cut</i>	[mm]	$n = \frac{v_c \times 1000}{\pi \times D}$
a_e = Werkstückbreite <i>Width of workpiece</i>	[mm]	$v_f = f_z \times n \times z_n$
v_c = Schnittgeschwindigkeit <i>Cutting speed</i>	[m/min]	
Q = Zerspanungsvolumen <i>Chipping volume</i>	[cm ³ /min]	$Q = \frac{a_p \times a_e \times v_f}{1000}$
t_c = Eingriffszeit <i>Processing time</i>	[min]	$t_c = \frac{l_f}{v_f}$
z_n = Anzahl der Schneiden <i>Number of cutting edges</i>	[Stück] [Piece]	
f_z = Vorschub pro Zahn <i>Infeed per cutting edge</i>	[mm]	$P_c = a_p \times f_z \times z_e \times k_c$
f_n = Vorschub pro Umdrehung <i>Infeed per rotation</i>	[mm]	
v_f = Vorschubgeschwindigkeit <i>Infeed speed</i>	[mm/min]	
n = Drehzahl <i>Number of revolutions</i>	[U/min] [r/min]	
P_c = Leistungsbedarf <i>Power requirement</i>	[kW]	
k_c = Spezifische Schnittkraft <i>Specific cutting force</i>	[N/mm ²]	
Drehen Turning		
D = Bearbeitungsdurchmesser <i>Processing Diameter</i>	[mm]	$v_c = \frac{\pi \times D \times n}{1000}$
v_c = Schnittgeschwindigkeit <i>Cutting Speed</i>	[m/min]	
n = Drehzahl <i>Number of revolutions</i>	[U/min] [r/min]	$n = \frac{v_c \times 1000}{\pi \times D}$
t_c = Eingriffszeit <i>Processing time</i>	[min]	
Q = Zerspanungsvolumen <i>Chipping volume</i>	[cm ³ /min]	$t_c = \frac{l_f}{f_n \times n}$
l_f = Bearbeitungslänge <i>Processing length</i>	[mm]	
f_n = Vorschub pro Umdrehung <i>Infeed per rotation</i>	[mm]	$R_{max} = \frac{f_n^2 \times 125}{r_\epsilon}$
R_{max} = Oberflächengüte <i>Surface quality</i>	[µm]	
r_ε = Schneidenradius <i>Cutting edge radius</i>	[mm]	
a_p = Spantiefe <i>Depth of cut</i>	[mm]	

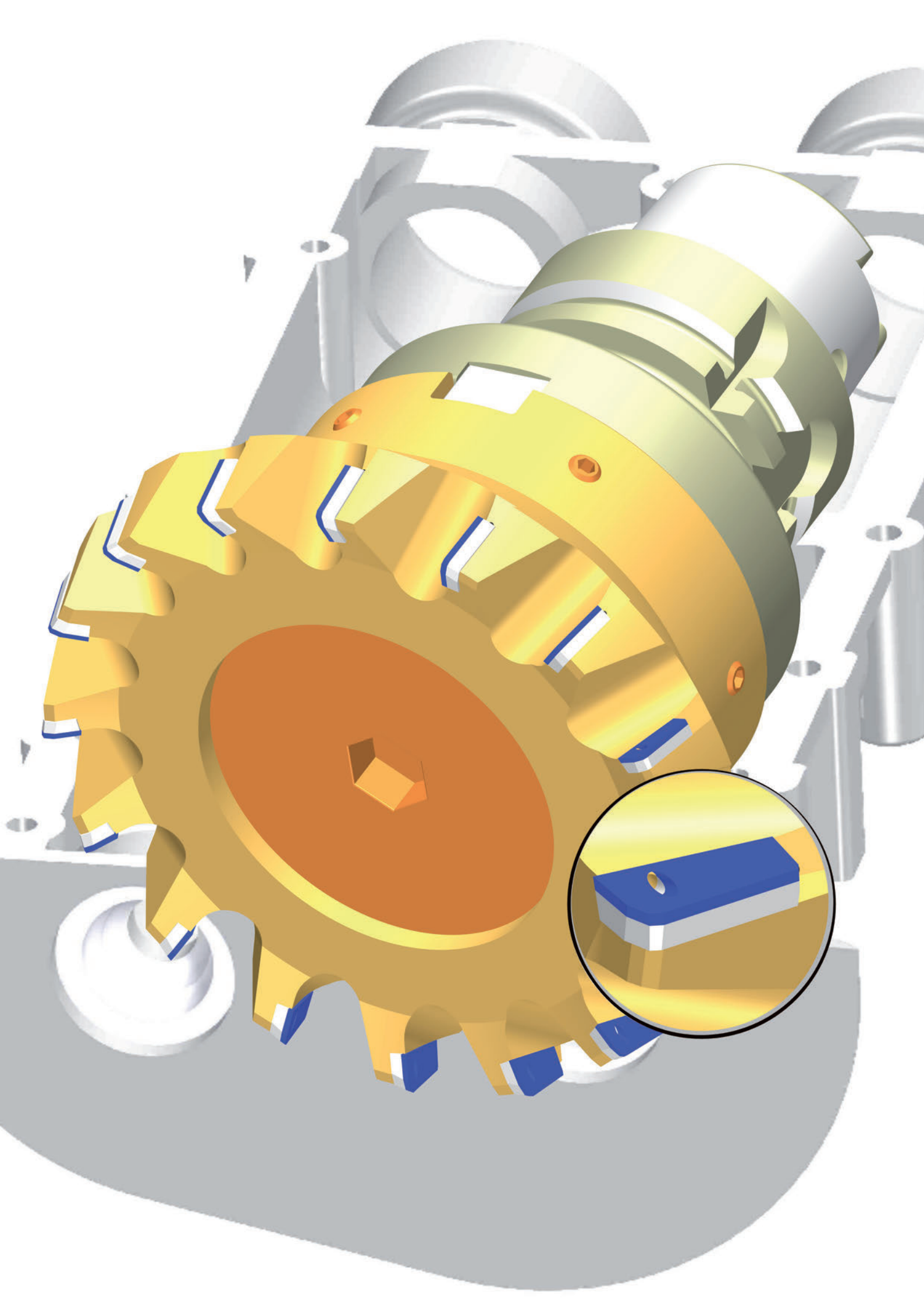

LACH-Diamant- und CBN-Fertigungsprogramm

Drehen, Bohren, Fräsen von NE-Metallen, gehärteten Stählen, Guss und Faser-Verbundwerkstoffen – GFK – CFK	dreborid® polykristalline Diamant- und CBN-Zerspanungs-Werkzeuge oder CVD-bestückt Besonderheiten: u. a. »chipbreaker«-Programm »Cool Injection« - Kühlung direkt
Schleifen von Hartmetall und Keramik	Diamant-Schleifscheiben und -Stifte in Kunststoff-, Metall-, Keramik- und Galvanik-Bindungen
Schleifen von HSS und gehärteten Stählen	CBN-Schleifscheiben und -Stifte in Kunststoff-, Metall-, Keramik- und Galvanik-Bindungen
Abrichten von Schleifscheiben	Natur-Einzel-Abrichtdiamanten, geschliffene Profil-, Kopier- und Diaform-Diamanten, Vielkorn-Diamant-Abrichter, Abrichtplatten und Aggregate, Präzisions-Diamant-Abrichtrollen, drebojet-Diamant-Fräs-Abrichtrollen, Rohdiamanten – auch zur Vorlage – aus eigenen Importen
Feilen, Entgraten, Trennen, Fräsen	Galvanikprogramm: Diamant-Trennscheiben für GFK, CFK etc. und Grünlingsbearbeitung von Hartmetall und Keramik, Diamant-Feilen, Entgratungs- und Profil- erzeuge
Läppen und Polieren	Diamant-Pasten und Diamant-Spray »MF«-Programm
Schleif- und Schärffmaschinen	für Service und Herstellung polykristalliner Diamant- und CBN-Werkzeuge
Service-Leistungen	Nachschleifen aller polykristallinen Diamant-, CBN- und CVD-Zerspanungs-Werkzeuge, Umfassen und Nachschleifen in eigener Natur-Diamant-Schleiferei von Einzel-Abrichtdiamanten, Profil-, Kopier- sowie Diaform-Diamanten und sonstigen Natur-Diamant-Werkzeugen, Wiederbelegung galvanisch gebundener Diamant- und CBN-Werkzeuge, CVD-Beschichtung von Verschleißteilen

LACH Diamond and CBN Manufacturing Programmes

<i>Turning, drilling, milling of non-ferrous metals, hardened steels, cast iron and fibre composite materials – GRP – CFRP</i>	<i>dreborid® polycrystalline diamond and CBN cutting tools or CVD-tipped Specialties: e.g. »chipbreaker« programme »Cool Injection« - direct cooling</i>
<i>Grinding of carbide and ceramics</i>	<i>Diamond grinding wheels and pins in resin, metal, vitrified and electroplated bond</i>
<i>Grinding of HSS and hardened steels</i>	<i>CBN grinding wheels and pins in resin, metal, vitrified and electroplated bond</i>
<i>Dressing of grinding wheels</i>	<i>Single-point natural diamond dressers, ground profile, copy and Diaform diamonds, multi-point diamond dressers, dressing plates and grit dressers, precision diamond dressing rolls, drebojet diamond mill dressing rolls, natural diamonds – from own imports for selection</i>
<i>Filing, deburring, cutting off, milling</i>	<i>Electroplated tool programme: diamond cutting discs for GRP, CFRP etc. and machining of green carbide and green ceramics, diamond files, deburring and profile tools</i>
<i>Lapping and polishing</i>	<i>Diamond lapping compounds and diamond spray »MF« programme</i>
<i>Grinding and sharpening machines</i>	<i>for service and manufacturing of polycrystalline diamond and CBN tools</i>
<i>Service</i>	<i>Resharpener of all polycrystalline diamond, CBN and CVD cutting tools, resetting and resharpener in our own natural diamond service facility of single-point diamond dressers, profile, copy as well as Diaform diamonds and other natural diamond tools, recoating of electroplated diamond and CBN tools, CVD-coating of wear parts</i>



Lach Diamond Inc., Grand Rapids, Michigan, USA



Stammwerk / Headquarters Hanau/Frankfurt/M.



Werk Sachsen / Plant Saxonia Lichtenau/Chemnitz

LACH DIAMOND INC.
 4350 Airwest Drive, S.E.
 Grand Rapids, MI, 49512 USA

Phone +1 (616) 698-0101
 Fax +1 (616) 698-0232
www.lachdiamond.com
office@lachdiamond.com

